

MADRE



→ **FLAMINIA.**

MADRE

ANGELETTI-RUZZA DESIGN

*«Tra il passato nostro e il nostro presente
non esiste incompatibilità.
Noi non vogliamo rompere con la tradizione:
è la tradizione che si trasforma,
assume aspetti nuovi, sotto i quali pochi la riconoscono.»*

*«Between our past and our present there
is no incompatibility. We do not want to break
with tradition: rather, it is tradition that undergoes
a transformation, takes on new facets,
and few recognise it in its new guise.»*

[parole tratte dalla rivista Rassegna Italiana del 1926,
manifesto del razionalismo italiano]

Madre è una collezione che guarda al lavoro degli architetti razionalisti italiani, tra cui Piero Bottoni. L'obiettivo è quello di progettare una stanza da bagno con un'anima classica che non imita gli stilemi del passato ma, al contrario, ne interpreta il senso e li trasporta nella contemporaneità con proporzioni completamente rinnovate con una continuità di linee ed andamenti che la rendono propriamente attuale. **Madre** evoca un senso di sicurezza e di stabilità, ispira una solida fiducia. Un design fuori dal tempo che crea un'atmosfera calda ed avvolgente.

Nel progettare una collezione di ceramica prodotta interamente in Italia ci siamo lasciati ispirare da un'architettura che ha segnato in maniera incisiva il nostro immaginario.

Madre is a collection that looks to the works of the architects of Italian rationalism, such as *Piero Bottoni*. The aim was to design a bathroom with a classic soul, which would not imitate the styles of the past, but rather would capture their intentions and transpose them into a contemporary version having totally renewed proportions and featuring a continuity of lines and rounded surfaces that made it perfectly current. **Madre** evokes a sense of self-confidence and stability, inspires total trust. Its timeless design creates a warm, enveloping atmosphere.

In designing a collection of fully Italian-made ceramic sanitary ware, we drew our inspiration from an architecture that has left a deep mark on our collective imagination.

 **FLAMINIA.**



MADRE 75 _ Latte
art. MA75L - 75 x 50 x h 14 cm



MADRE _ Latte
art. MA117G/MA217 - 55 x 37 x h 45 cm



MADRE 75 _ Latte
art. MA75L - 75 x 50 x h 14 cm







MADRE _ Grafite
art. MA117G/MA217 - 55 x 37 x h 45 cm



MADRE 75 _ Grafite
art. MA75L - 75 x 50 x h 14 cm



MADRE 95 _ Grafite
art. MA95L - 95 x 50 x h 14 cm



MADRE 95

art. MA95L - 95 x 50 x h 14 cm

MADRE

art. MA117G/MA217 - 55 x 37 x h 45 cm



MADRE

art. **MA75L** - dim. 75 x 50 x h 14 cm
 Lavabo **MADRE 75** da appoggio / sospeso
MADRE 75 countertop / wall hung basin

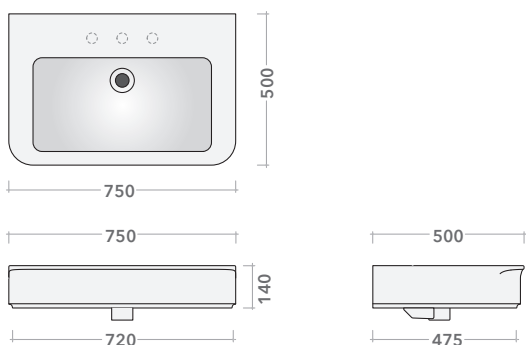

art. **MA95L** - dim. 95 x 50 x h 14 cm
 Lavabo **MADRE 95** da appoggio / sospeso
MADRE 95 countertop / wall hung basin

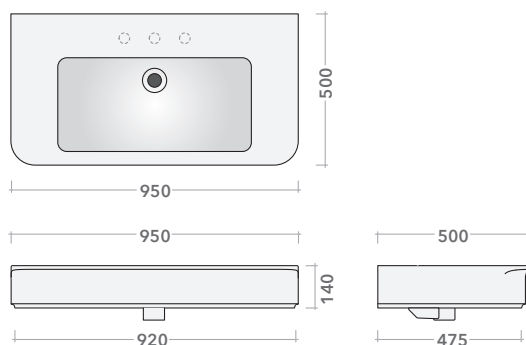

art. **MA117G** - dim. 55 x 37 x h 45 cm
MADRE vaso back to wall scarico S/P
 con sistema **goclean®**
MADRE back to wall wc S/P trap
 with **goclean®** system

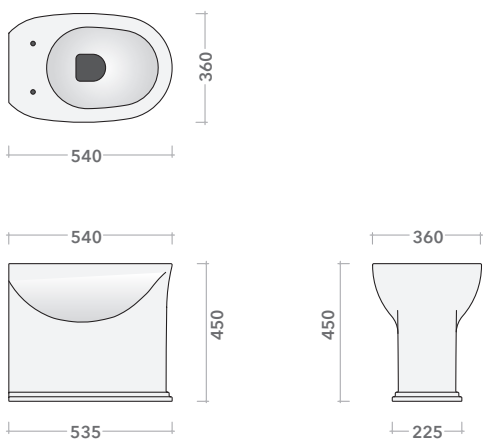

art. **MA217** - dim. 55 x 37 x h 45 cm
MADRE bidet back to wall monoforo
MADRE back to wall single hole bidet

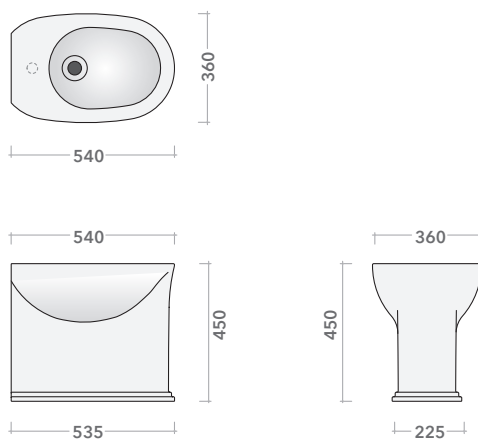

ADMEMBER

Ceramics of Italy

Quality Management System
UNI EN ISO 9001

Environmental Management System
UNI EN ISO 14001

Spazio Flaminia Showroom
via Solferino, 18 - Milano
t. +39 02 89055303 **f.** +39 02 89055490
spazioflaminia@ceramicaflaminia.it

Ceramica Flaminia Spa
S.S. Flaminia km. 54,630 - Civita Castellana VT
t. +39 0761 542030 **f.** +39 0761 540069
ceramicaflaminia@ceramicaflaminia.it

→ FLAMINIA.

Copyright
Flaminia 2018

Flaminia art direction
Giulio Cappellini

Catalog art direction and graphic design
Giulio Cappellini
Flaminia

Render
Telligraf

Flaminia is a registered trademark
of Ceramica Flaminia Spa

www.ceramicaflaminia.it

→ FLAMINIA.